

Flame

Installation Guide

Main Material of Manufacture - Aluminium



Attention The connection of this radiator to a central heating system should be carried out by a suitably competent person who is familiar with current regulations.

Read this guide before starting installation

Handling Advice

Please refer to the manual handling guidelines that are supplied with this product. This gives important information about the safe lifting of these radiators to minimise risk and damage.

Water Treatment

These products are for use on closed heating systems only; they are not suitable for installation on secondary HWS circuits.

On completion of the installation the entire system **MUST** be thoroughly cleaned and flushed to remove debris/flux residues etc. If a chemical cleanser is used, it must be thoroughly flushed from the system. Following this, the system **MUST** be dosed with a good quality water treatment to prevent corrosion. System design, flushing and dosing must be in accordance with BS 5449: 1990, BS EN 12828: 2003 and BS 7593: 1992

IMPORTANT: Failure to observe these requirements will render the guarantee on the product void.

Corrosion inhibitor must be used in accordance with the manufacturer's instructions and recommendations and should take into account the particular metals within the system.

Cleaning & Aftercare

The external surface of the radiator should be cleaned with mild detergent if anodised or coloured finish, use surgical spirit if polished. No solvents or abrasives should be used.

Operating Pressure

Maximum 5 bar

Commissioning

The construction of this style of radiator produces a hydraulic resistance a little higher than that found with standard type radiators of a similar output, therefore particular care may be necessary when balancing the heating system to ensure thorough and even heating of this product. Consideration should be given to the selection of the circulation pump with a high head model possibly being necessary.

Further Information

These radiators have been designed, manufactured and tested to ensure a long-lasting use. Should you require any further information, help or advice, or have any difficulties with these products or their installation and use, please contact our office on:

Tel: **01268 546700** Fax: **01268 888250**

Web: **www.mhsradiators.com**

write to: 3 Juniper West, Fenton Way, Southfields Business Park, Basildon, Essex SS15 6SJ

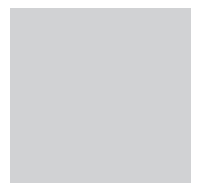
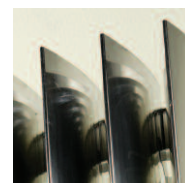

Installation Instructions

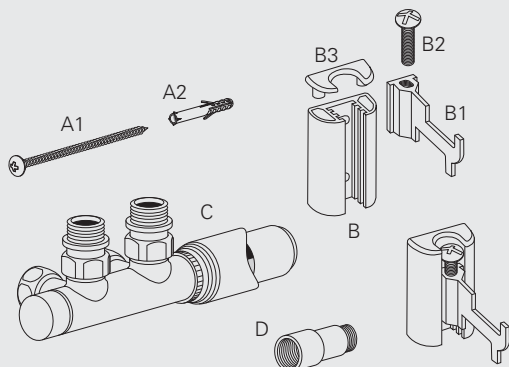

Installation Accessories:

- A1)** Screws for wall mounting
- A2)** Wall Plugs
- B)** Bracket back plate
- B1)** Adjustable support arm
- B2)** Support arm screw
- B3)** Decorative cap for back plate
- C)** Optional twin valve assembly
- D)** 1/2" x 3/8" MF long reach adaptor - allows connection of optional twin valve

A: Preparation of radiator

- 1:** If the radiator is to be connected using a TBSE* or TBOE* arrangement, then the baffle plug must be removed from the lower water manifold. Temporarily remove plug "5" and lightly insert a sharp wood screw into the rubber baffle plug located in the manifold and pull out and discard rubber plug. Tightly re-fit plug "5". Rubber plug must not be removed if using bottom opposite end connections.
- 2:** According to water connection arrangement to be used, install radiator valves, plugs and air vents into tappings 1,2,3,4 as appropriate, or install a twin valve "C" (utilising the 1/2" x 3/8" MF Adaptors supplied) into tappings in the underside of lower water manifold. Note: This radiator has 6 tappings - ensure that no tappings are left open.

B: Wall Mounting of Radiator

Radiators of 6 and 8 elements require 2 brackets to support the upper manifold and 1 bracket to support the lower manifold. For radiators of 10 elements one extra bracket is required at both manifolds, and for 12 elements two extra brackets at both manifolds are necessary.

- 1:** Measure distance from underside to underside of manifolds and note as d1.
- 2:** Make a light mark on the wall corresponding to final installed position of the bottom of the radiator.
- 3:** Make a mark referred to as L1 on the wall 18mm below the bottom of radiator mark.
- 4:** Mark a mark referred to as L2 on the wall d1mm above L1.
- 5:** Lightly scribe out horizontally level lines at L1 & L2 on the wall at the radiator installation position. These lines indicate the position of the bottom of the wall mounting brackets.
- 6:** Mark fixing points for the brackets at Line L2 by offering up the brackets so that the bottom edge of the bracket backplate corresponds with the line, and at locations so that the support arm is positioned centrally between the first and second elements and the penultimate and last elements. Similarly, mark fixing points for the lower bracket(s) at Line L1. If one bracket only is being used, locate it to support at the centre of the manifold. In the case of extra brackets at the upper and lower manifolds, position them to spread the load as evenly as possible.
- 7:** Using suitable fixings, secure the brackets to the wall.
- 8:** Insert adjustable support arms into backplates and retain with the machine screws provided. Initially set the position of the arms so that the rear part is centrally located in the back plate. Insert decorative caps into backplates.
- 9:** Offer up the radiator and engage upper and lower manifolds into the cradle notches on the bracket support arms and adjust arm positions if necessary to ensure the radiator is stable and level.

* TBSE = Top & Bottom Same End Connections

* TBOE = Top & Bottom Opposite End Connections

