

DECK

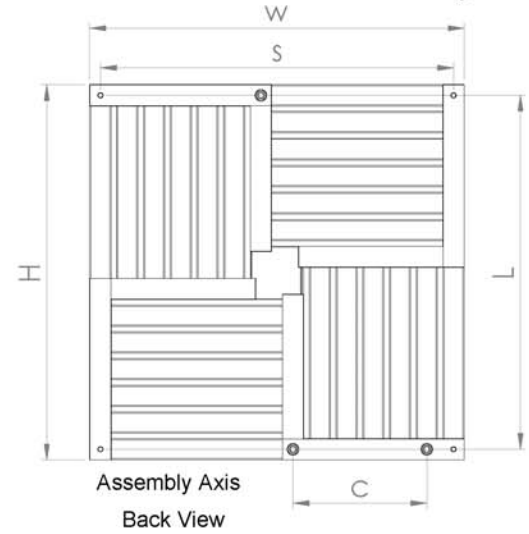
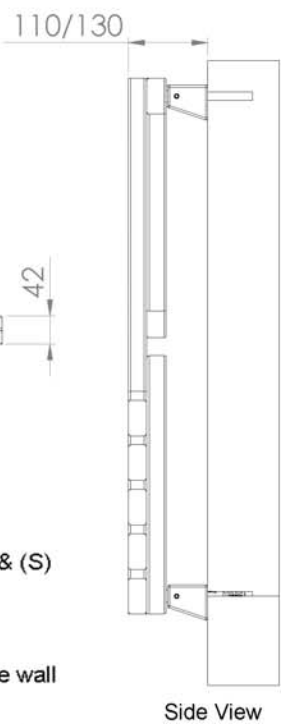
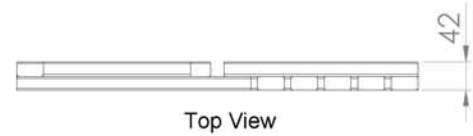
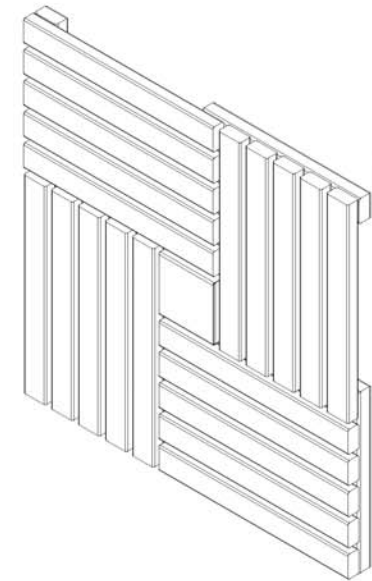
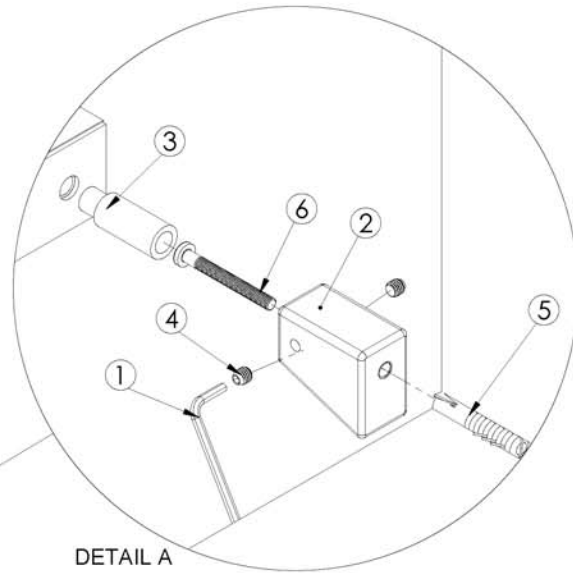
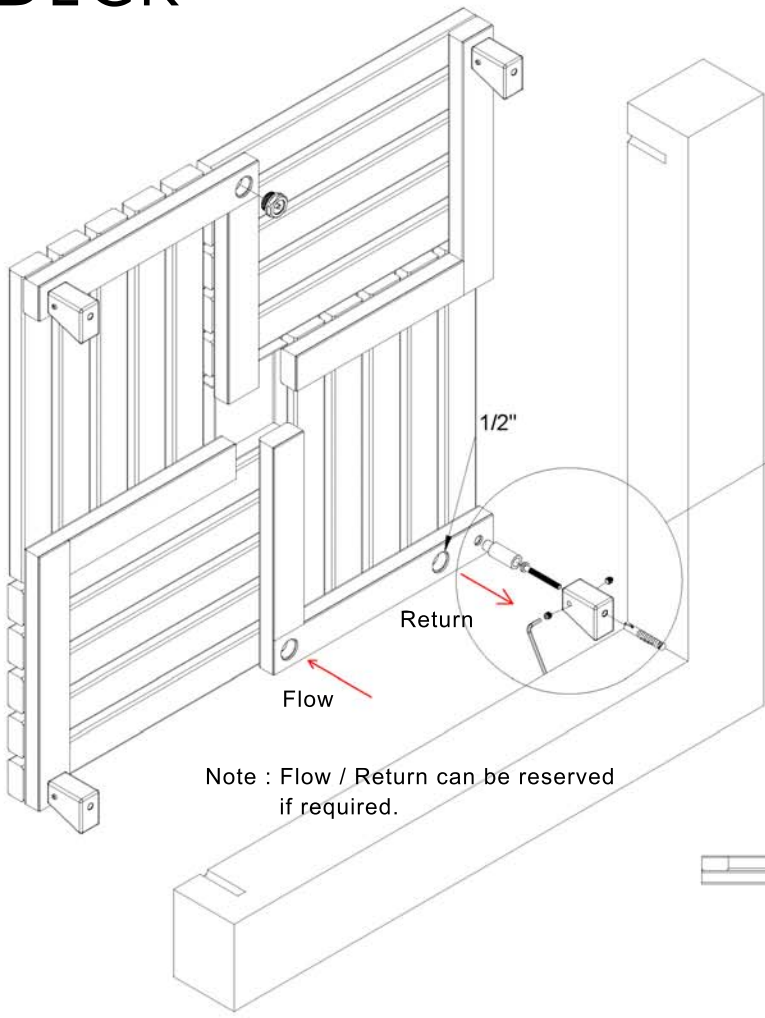

- 1- Allen Key 1 pcs
- 2- Bracket 4 pcs
- 3- Long Pillar Nut 4 pcs
- 4- Grub Screw 8 pcs
- 5- Wall Plug 4 pcs
- 6- Screw, dia 6mm. 4 pcs
- 7- Air Vent 1 pcs
- 8- Blanking Plug 1 pcs

Wall Mounting Instructions:

- 1- According to the relative wall connection axis (L) & (S) drill 4 Nr holes 10 mm.Ø x 50 mm. depth.
- 2- Insert wall plugs (5) into the drilled holes.
- 3- Screw the brackets (2) with the screws (6) into the wall plugs (5).
- 4- The Long Pillar Nuts (3) are screwed into the collectors at the back of the radiator as shown in detail C.
- 5- Offer up the radiator and insert the long pillar nuts (3) into the brackets (2).
- 6- Using the allen key (1) provided, retain the long pillar nuts (3) into the brackets (2) with the grub screws (4).

Water Connections : 1/2" BSP
 Not suitable for use with direct hot water systems. Not suitable for gravity circulation.

Product Code	Width	Height	Conn. Centers	Assembly Axis		No. Of Tubes
	W	H	C	S	L	
DECK0600-0600	600	600	200	560	560	20
DECK0700-0700	700	700	250	660	660	24

*All measurements are in millimetres
 This publication is issued subject to alteration or withdrawal without notice