

AQUILA

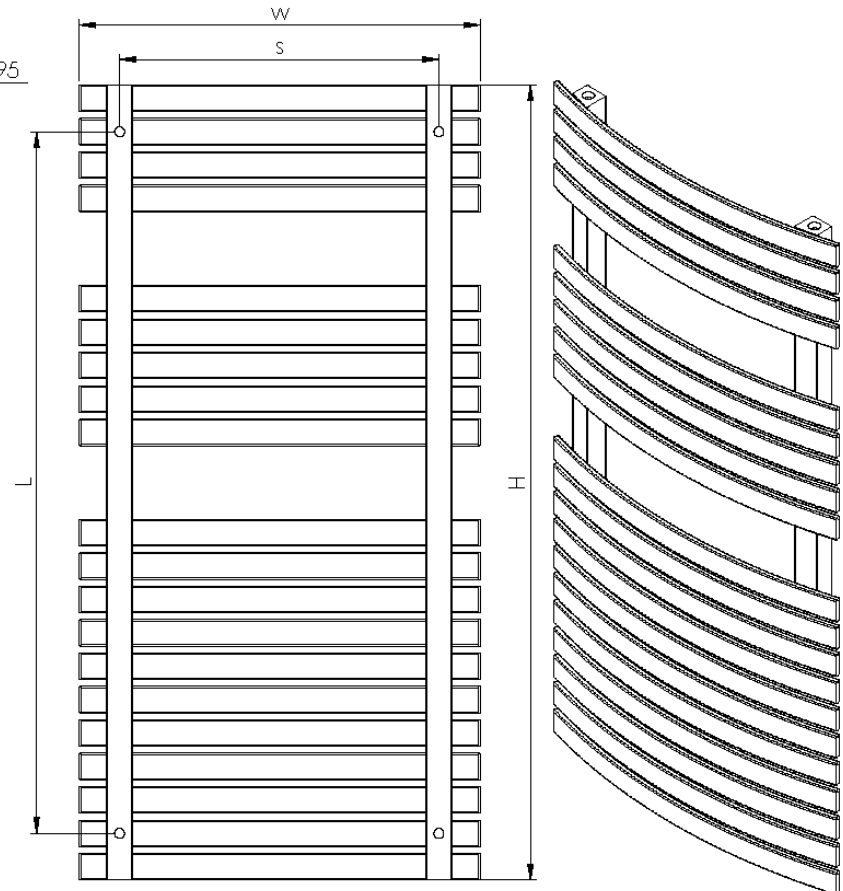

Note: Flow / Return can be reserved if required

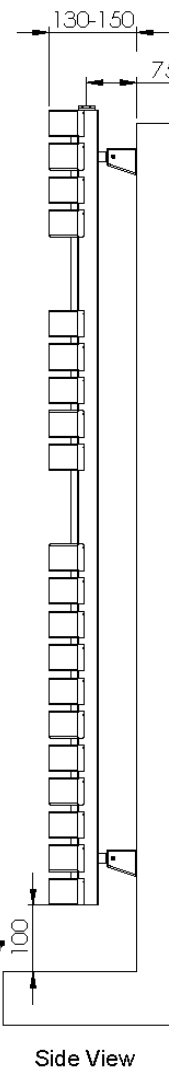
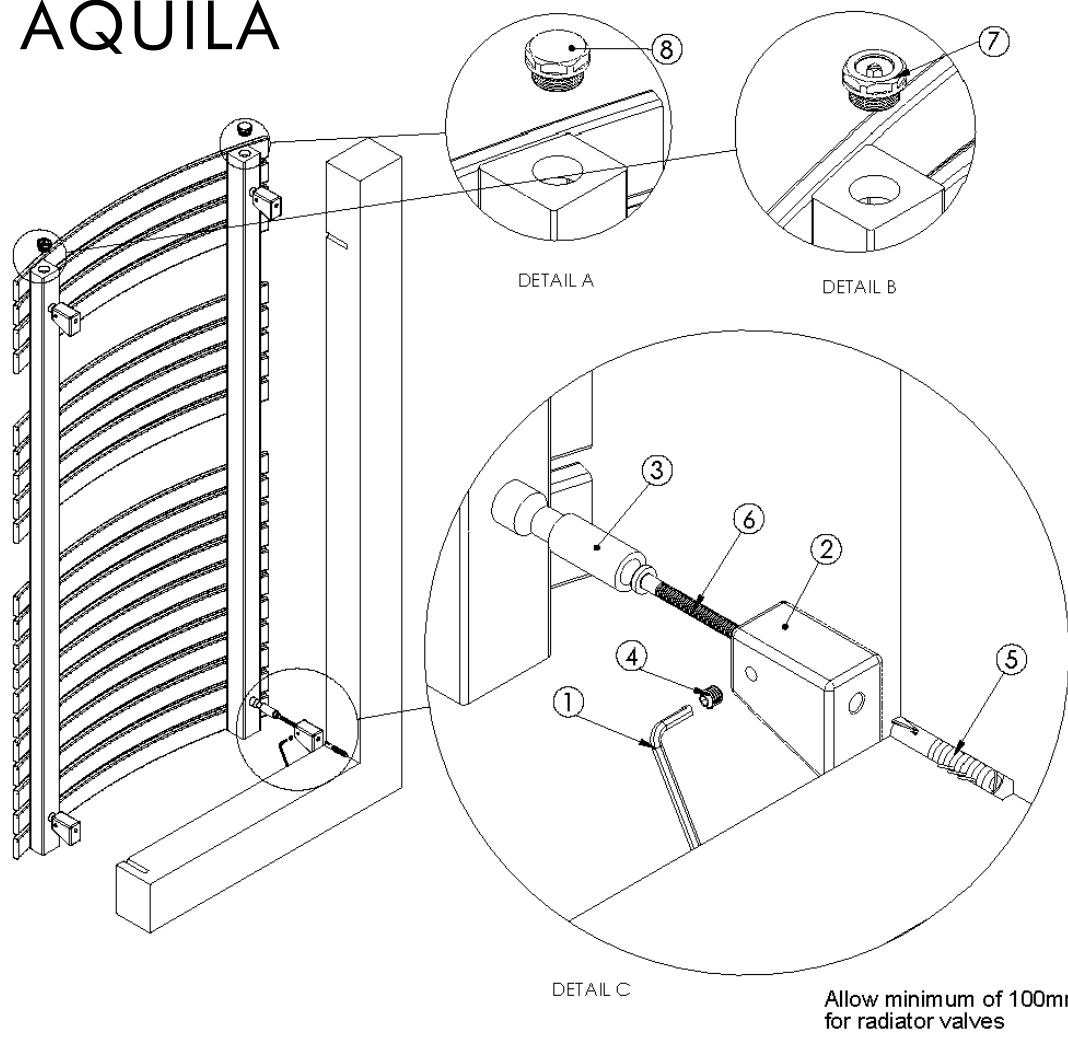
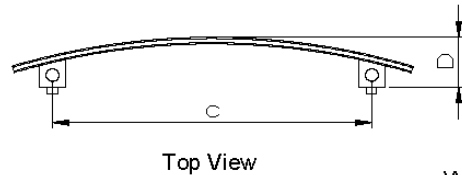

Water Connections : 1/2" BSP

Not suitable for use with direct hot water systems. Not suitable for gravity circulation.

- 1- Allen Key 1 pcs
- 2- Bracket 4 pcs
- 3- Short Pillar Nut 4 pcs
- 4- Grub Screw 8 pcs
- 5- Wall Plug 4 pcs
- 6- Screw, dia 6mm. 4 pcs
- 7- Air Vent 1 pcs
- 8- Blanking Plug 1 pcs

Wall Mounting Instructions:

- 1- According to the relative wall connection axis (L) & (S) drill 4 Nr holes 10 mm.Ø x 50 mm. depth.
- 2- Insert wall plugs (5) into the drilled holes.
- 3- Screw the brackets (2) with the screws (6) into the wall plugs (5).
- 4- The Short Pillar Nuts (3) are screwed into the collectors at the back of the radiator as shown in detail C.
- 5- Offer up the radiator and insert the short pillar nuts (3) into the brackets (2).
- 6- Using the allen key (1) provided, retain the short pillar nuts (3) into the brackets (2) with the grub screws (4).

Product Code	Width	Height	Conn. Centers	Assembly Axis		Depth	No. Of Tubes
	W	H	C	S	L		
AQUS50/79	500	790	380	380	650	65	14
AQUS50/119	500	1190	380	380	1050	65	20
AQUS60/119	600	1190	480	480	1050	75	20